

Transfer or duplication of this document as well as the utilisation or communication of its content are not permitted unless express consent is granted. Violations give rise to claims for damages. All rights reserved in case of patent, utility model or design patent registrations.

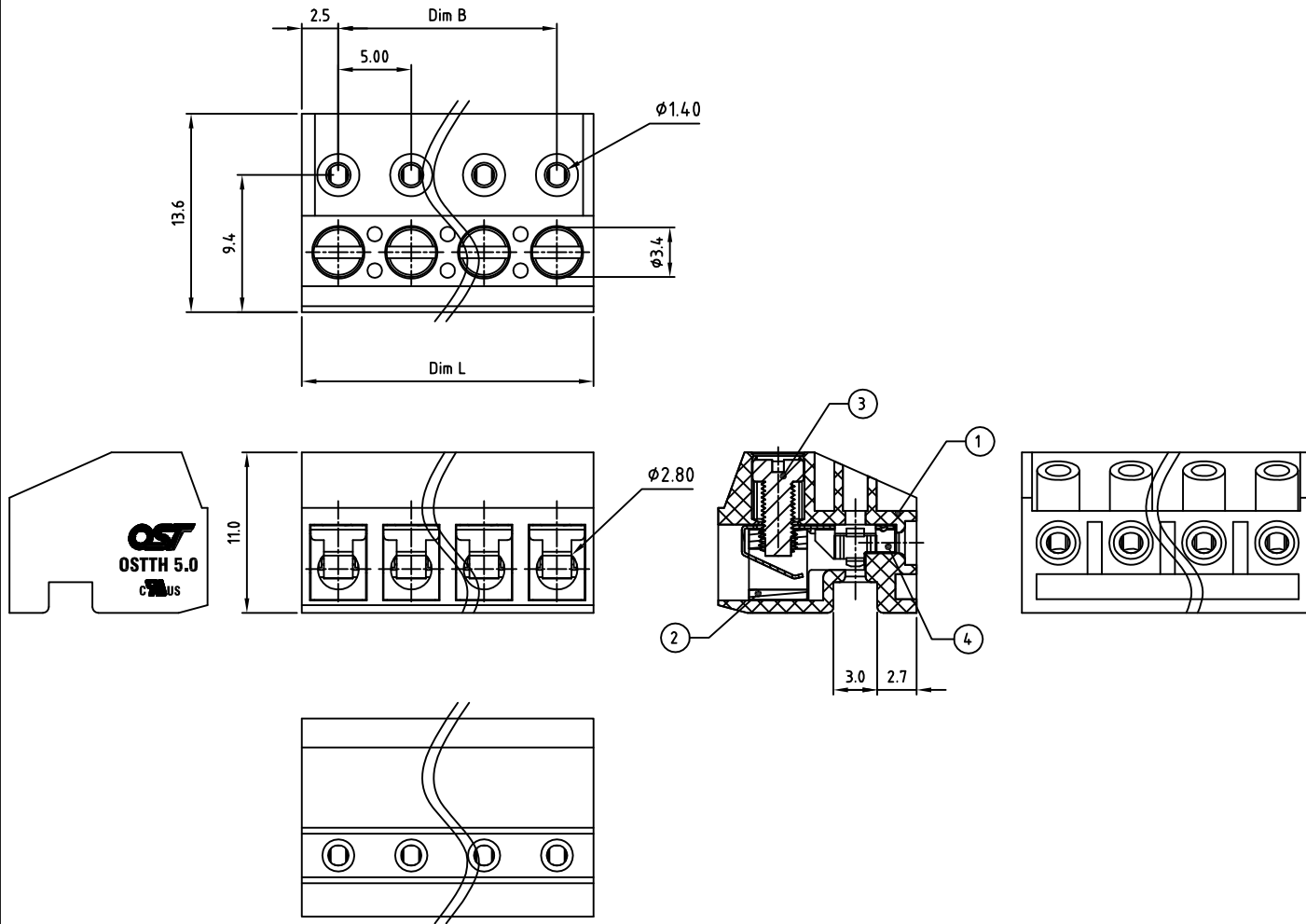

**Technical data**

1. Nominal voltage: 300V/14A  
PITCH: 5.0mm
2. Connection capacity:  
AWG 22-14
3. Insulation Withstanding Voltage:  
AC 1600V/MIN
4. Insulation Resistance:  
1000MΩ or more at DC500V
5. Tightening torque:  
4.0kgf.cm (0.4N.m)
6. Screw thread: M2.6
7. Stripping length: 5-6mm
8. Operating temperature range: -40°C ~ 115°C
9. Undimensioned Tolerances:

Dim.L = P x 5.0		
Dim.B = (P - 1) x 5.0		
P = number of poles (2-24p)		
	Dim B	Dim L
0-30mm	±0.15	±0.20
over 30mm-60mm	±0.20	±0.25
over 60mm-90mm	±0.25	±0.30
over 90mm	±0.30	±0.40

10. Safety approval:
11. RoHS Compliance

Part No: **OSTTHXX0101**

<p>No. of Poles</p> <p>02 2 Poles</p> <p>03 3 Poles</p> <p>... ..</p> <p>24 24 Poles</p>	<p>COLOR</p> <p>0: Black (Standard)</p> <p>2: Red</p> <p>3: Orange</p> <p>4: Yellow</p> <p>5: Green</p> <p>6: Blue</p> <p>8: Grey</p>
--	---

Nonstandard colors  
Mins could apply

4	WIRE GUARD	PhBz t=0.20mm			P
3	SCREW	STEEL		M2.6x0.4, Zn Plated	P
2	CAGE	BRASS		M2.6x0.4, Tin PLATED	P
1	BODY	PA66 UL94V-0		Black	1
ITEM	NAME OF PART	MATERIAL	NOTES		Q'TY
DWG	WF. Zhang	DATE 2017.08.11	UNITS: MM	SHEET: 1 OF 1	Tolerance
CHK.	WF. Zhang	DATE 2017.08.11	SCALE: NONE 2.5:1 ( : )	REV: A	X. ±0.50
APP.		DATE	TITLE: OSTTH 5.0 Series Solid block "-" slot type 2-24p		X.XX ±0.30
			PART NO. OSTTHXX0101		X* ±1°
			DWG NO. OSTTHXX0101.dwg		

SIGN	DESCRIPTION	CHK.	DATE	ON-SHORE TECHNOLOGY, INC.

