

Transfer or duplication of this document as well as the utilisation or communication of its content are not permitted unless express consent is granted. Violations give rise to claims for damages. All rights reserved in case of patent, utility model or design patent registrations.

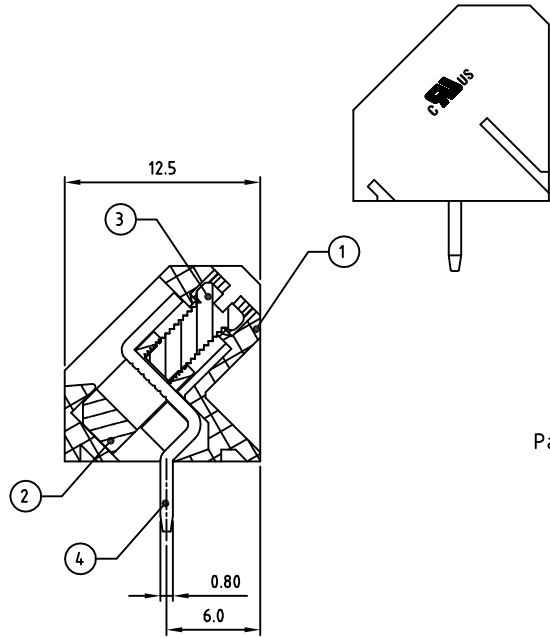
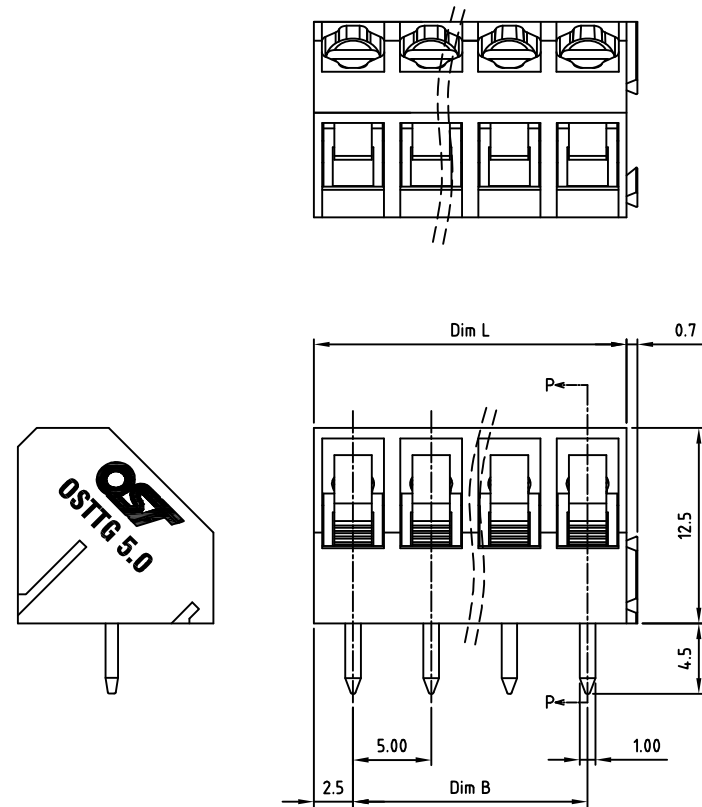

- Technical data
- Nominal voltage: 300V/15A
PITCH:5.0mm
 - Connection capacity:
AWG 24-12
 - Insulation Withstanding Voltage:
AC 1600V/MIN
 - Insulation Resistance:
1000MΩ or more at DC500V
 - Tightening torque:
4.0kgf.cm (3.5Lb-In / 0.4N.m)
 - Screw thread: M2.5
 - Stripping length: 6-7mm
 - Operating temperature range:-40°C ~ 115°C
Soldering temperature:250°C±10°C /5s
 - Undimensioned Tolerances:

Dim.L=Px5.0 Dim.B=(P-1)x5.0 P= number of poles		
0-30mm	Dim B ±0.15	Dim L ±0.20
over 30mm-60mm	±0.20	±0.25
over 60mm-90mm	±0.25	±0.30
over 90mm	±0.30	±0.40

- Safety approval:
- RoHS Compliance

Part No.: **OSTTGXX0160C**

No. of Poles	COLOR
02 2 Poles	0: Black
03 3 Poles	2: Red
...	3: Orange
24 24 Poles	4: Yellow
	5: Green
	6: Blue (Standard)
	8: Grey

Nonstandard colors
Mins could apply

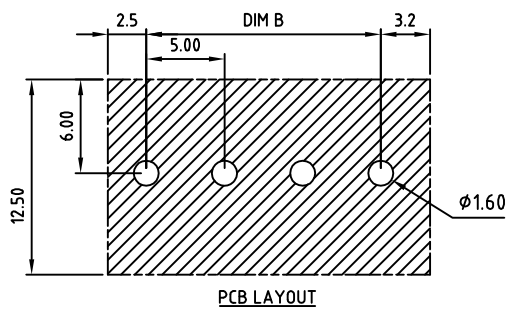

PCB LAYOUT

4	CONTACT	BRASS	Tin PLATED	P	
3	SCREW	STEEL	M2.5x0.45, Zn Plated	P	
2	CAGE	BRASS	M2.5x0.45, Ni PLATED	P	
1	BODY	PA66 UL94V-0	ALL COLOR	1	
ITEM	NAME OF PART	MATERIAL	NOTES	Q"TY	
DWG	WF. Zhang	DATE 2018.06.07	UNITS: MM	SHEET: 1 OF 1	Tolerance
CHK	WF. Zhang	DATE 2018.06.07	SCALE: NONE 3:1 (:)	REV: A	X. ±0.50
APP		DATE	TITLE: OSTTG 5.0 Series Solid block type "-" slot screw type		X,XX ±0.30
			PART NO. OSTTGXX0160C		X* ±1.0
			DWG NO. OSTTGXX0160C.dwg		±1°

SIGN	DESCRIPTION	CHK.	DATE



ON-SHORE TECHNOLOGY, INC. DWG NO. OSTTGXX0160C.dwg