

Transfer or duplication of this document as well as the utilisation or communication of its content are not permitted unless express consent is granted. Violations give rise to claims for damages. All rights reserved in case of patent, utility model or design patent registrations.

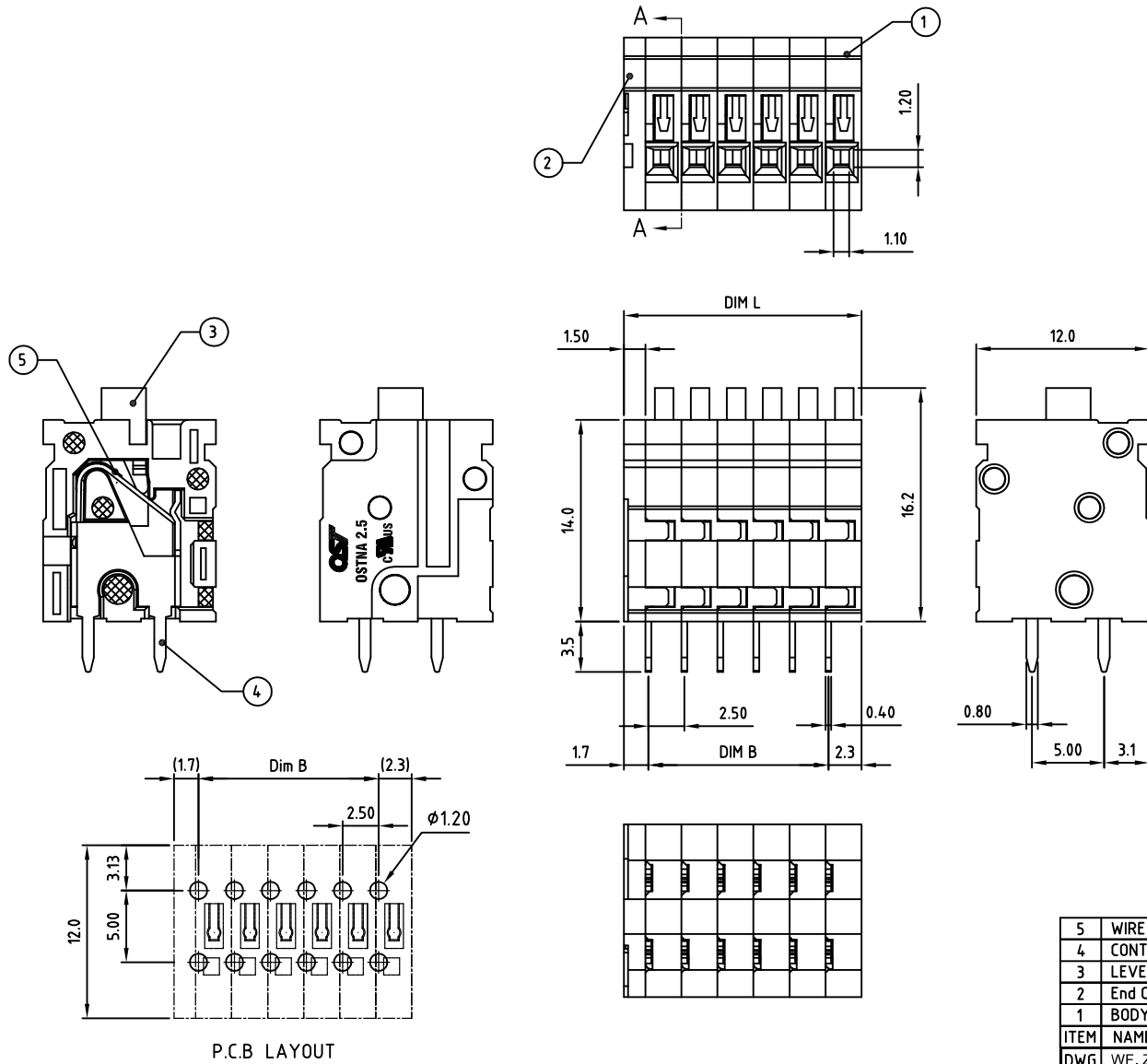

Technical data

1. Nominal voltage: 150V/6A
PITCH: 2.5mm
2. Connection capacity:
AWG 26-18
3. Insulation Withstanding Voltage:
AC 1600V/MIN
4. Insulation Resistance:
1000MΩ or more at DC500V
5. Stripping length: 9-10mm
6. Operating temperature range: -40°C ~ 115°C
Soldering temperature: 250°C ± 10°C / 5s
7. Undimensioned Tolerances:

Dim.L = P x 2.5 + 1.5		
Dim.B = (P - 1) x 2.5		
P = number of poles (1-24P)		
	Dim B	Dim L
0-30mm	±0.15	±0.20
over 30mm-60mm	±0.20	±0.25
over 60mm-90mm	±0.25	±0.30
over 90mm	±0.30	±0.40

8. Safety approval:

9. RoHS Compliance

Part No.: **OSTNAXXB080**

No. of Poles	COLOR
02 2 Poles	0: Black
03 3 Poles	2: Red
...	3: Orange
24 24 Poles	4: Yellow
	5: Green
Nonstandard colors	6: Blue
Mins could apply	8: Grey (Standard)

5	WIRE GUARD	Stainless steel		P
4	CONTACT	BRASS		P
3	LEVEL	PA66 UL94V-0		P
2	End COVER	PA66 UL94V-0		1
1	BODY	PA66 UL94V-0		P
ITEM	NAME OF PART	MATERIAL	NOTES	Q'TY
DWG	WF. Zhang	DATE	2017.08.27	UNITS: MM SHEET: 1 OF 1 Tolerance
CHK.	WF. Zhang	DATE	2017.09.06	SCALE: NONE 4:1 (:) REV: A X. ±0.50
APP.		DATE		X.XX ±0.30
		TITLE:	OSTNA 2.5 Series 90D wire inlet (Vertical)	X* ±0.10
		PART NO.	OSTNAXXB080	X* ±1°
		DWG NO.	OSTNAXXB080.dwg	

SIGN	DESCRIPTION	CHK.	DATE



ON-SHORE TECHNOLOGY, INC.