

Transfer or duplication of this document as well as the utilisation or communication of its content are not permitted unless express consent is granted. Violations give rise to claims for damages. All rights reserved in case of patent, utility model or design patent registrations.

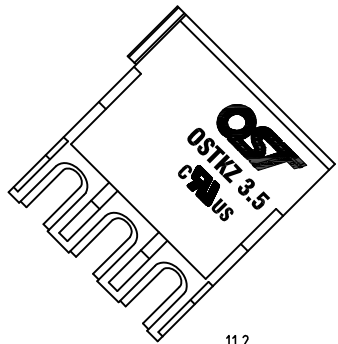
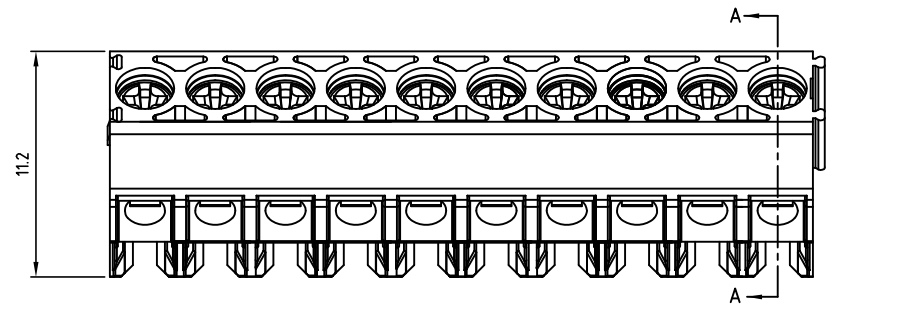

- Technical data**
- Nominal voltage: 300V/10A
PITCH:3.5mm
 - Connection capacity:
AWG 26-16
 - Insulation Withstanding Voltage:
AC 1600V/MIN
 - Insulation Resistance:
500MΩ or more at DC500V
 - Tightening torque:
2.0kgf.cm (0.2N.m)
 - Screw thread: M2
 - Stripping length: 4-5mm
 - Operating temperature range: -40°C - 115°C
Soldering temperature: 250±10°C/5s
 - Undimensioned Tolerances:

| | | |
|---------------------------|-------|-------|
| Dim.L=P×3.5 | | |
| Dim.B=(P-1)×3.5 | | |
| P= number of poles(2-24P) | | |
| 0-30mm | ±0.10 | ±0.15 |
| over 30mm-60mm | ±0.15 | ±0.20 |
| over 60mm-90mm | ±0.20 | ±0.25 |
| over 90mm | ±0.25 | ±0.30 |

- Safety approval:
- RoHS Compliance

Part No.: **OSTKZXX1051**

| | |
|--|---------------------|
| No. of Poles | COLOR |
| 02 2 Poles | 0: Black |
| 03 3 Poles | 2: Red |
| ... | 3: Orange |
| 24 24 Poles | 4: Yellow |
| | 5: Green (Standard) |
| | 6: Blue |
| Nonstandard colors Mins could apply | 8: Grey |

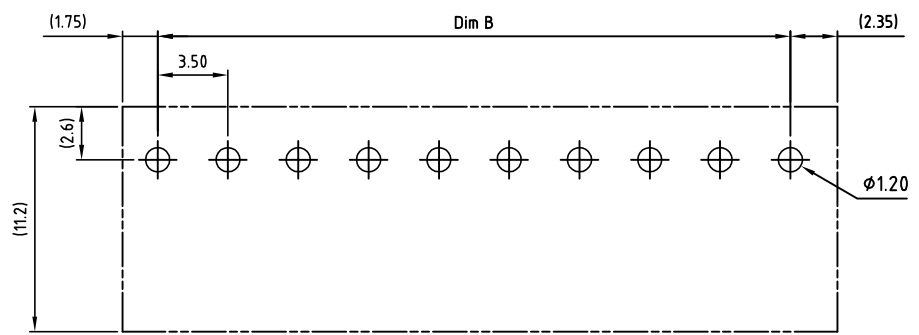
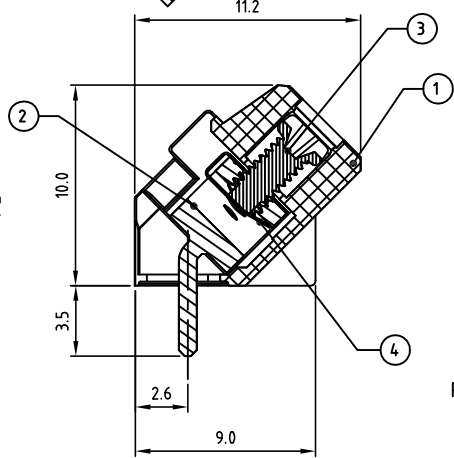
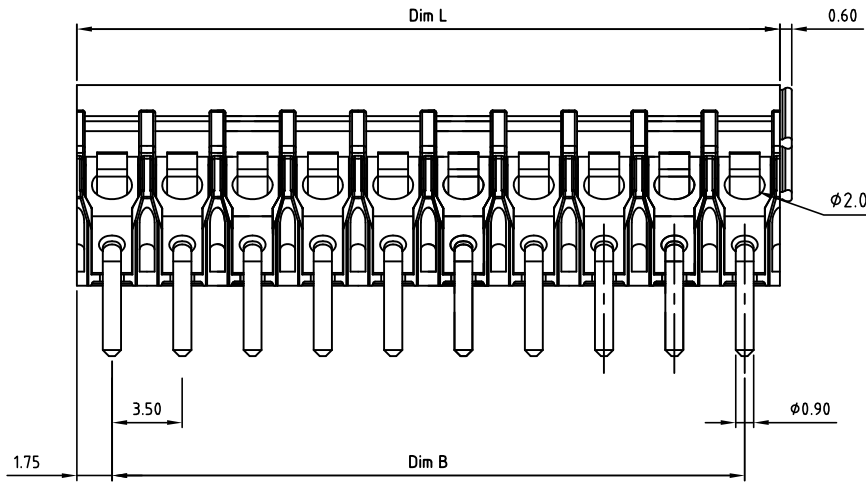

| 4 | WIRE GUARD | Stainless steel | | 10 |
|------|--------------|-----------------|------------------|--|
| 3 | SCREW | STEEL | M2.0, Zn Plated | 10 |
| 2 | CAGE | BRASS | M2.0, Tin PLATED | 10 |
| 1 | BODY | PA66 UL94V-0 | Black | 1 |
| ITEM | NAME OF PART | MATERIAL | NOTES | Q'TY |
| DWG. | WF. Zhang | DATE | 2015.04.25 | UNITS: MM SHEET: 1 OF 1 Tolerance |
| CHK. | | DATE | | SCALE: NONE 4:1 (:) REV.: A X. ±0.50 X.X ±0.30 X.XX ±0.10 X* ±1° |
| APP. | | DATE | | TITLE: OSTKZ Series 3.50mm black +/- slot screw type |
| | | | | PART NO. OSTKZXX1051 |
| | | | | DWG NO. OSTKZXX1051.dwg |

| | | | |
|------|-------------|------|------|
| | | | |
| SIGN | DESCRIPTION | CHK. | DATE |



ON-SHORE TECHNOLOGY, INC.