

Transfer or duplication of this document as well as the utilisation or communication of its content are not permitted unless express consent is granted. Violations give rise to claims for damages. All rights reserved in case of patent, utility model or design patent registrations.

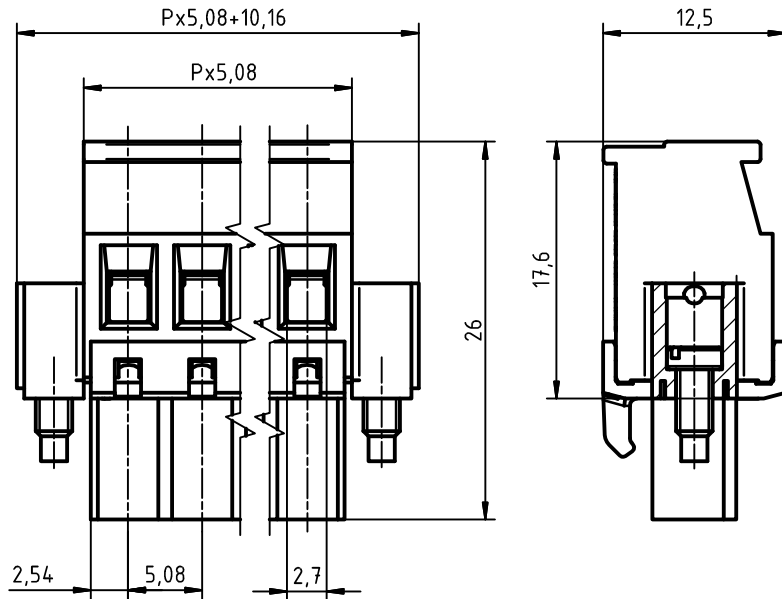

Ratings

Use Group	B	D
Rated Voltage	300V	300V
Rated Current	15A	10A
Rated Wire Size		
solid	AWG 28-12	AWG 28-12
flexible	AWG 28-12	AWG 28-12

Screw Size M3

Insulating Material

Material PA 6.6
Flammability Class UL 94 V-0

Materials

Clamp Brass
Screw Steel
Solder Tag Bronze
Temperature Range -40° C ~ 105° C

RoHS Compliant

Part No.: **EDZ1111/XX**

No. of Poles
02 2 Poles
03 3 Poles
...
20 20 Poles

DWG	WF. Zhang	DATE	2017.09.11	UNITS:	MM	SHEET:	1 OF 1	Tolerance
CHK.	WF. Zhang	DATE	2017.09.11	SCALE:	NONE 5:1 (:)	REV:	A	X. ±0.50
APP.		DATE		TITLE:	EDZ1111 series 5.08 mm			X.X ±0.30
				PART NO.	EDZ1111/XX			X.XX ±0.10
				DWG NO.	EDZ1111XX.DWG			X° ±1°

⚠			
SIGN	DESCRIPTION	CHK.	DATE



ON-SHORE TECHNOLOGY, INC.

